



SD380

Handheld Contact to Middle Range Linear Imager Barcode Scanner

SCANTECH ID[®]
CHAMPTEK Group

Introduction

The SD380 linear imager barcode scanner brings unmatched performance along with the latest advanced technology to the point-of-sale checkout operations, and it is a reliable bar code reader suitable for a wide range of environments. The SD380's features and its outstanding price-performance ratio make it the best solution for retail and light industrial applications.

The SD380 provides a 'black' or 'warn gray' color option, emphasizing the curving lines of the new enclosure and supports keyboard wedge, RS232 and USB interface. The powerful built-in decoder reads and discriminates all major 1D bar codes and GS1 DataBar™ symbologies, including damaged or poorly printed codes, reducing processing time and labor costs, while increasing accuracy.

Its barcode programming menus provides extensive configuration options. A stand or holder option can be ordered to facilitate hand-free reading option and configured to its automatic wake-up reading can extend its lifespan.

The SD380 provides customers with the most cost-effective solution in the market and is the best choice for any retail environments.

Features

- The best price-performance ratio solution in the market for retail and light industrial applications.
- Available for Gray and Black color choice.
- Reading depth from window up to 200mm.
- Support minimum resolution 4 mil/0.1 mm.
- Reads most 1D bar code symbologies include GS1 Databar codes.
- Support multiple Interface options, USB / RS-232 / Keyboard Wedge.
- A stand or holder option can be ordered to facilitate hand-free reading options.

SD380

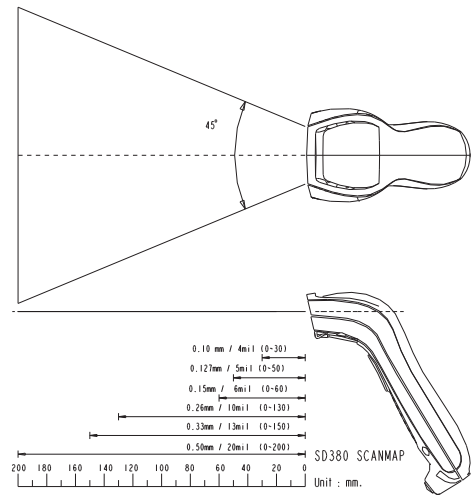
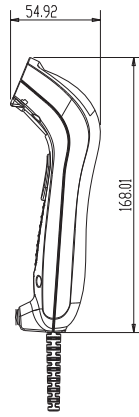
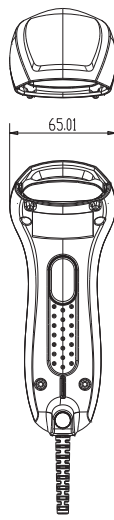

Specification

Physical Characteristics

Weight	
Body weight	Approx. 90g
Cable weight	Approx. 60g
Material	
	ABS
Dimension	
	65.01mm W x 168.01mm D x 54.92mm H

Electrical Characteristics

Interface	RS232	USB	KB
Supply Voltage	DC +5V ±5%		
Output Voltage (Typ.)	±9V	+5V±5%	+5V±5%
Output low Voltage (Max.)	-	0.7V	0.7V
Current Draw	±10%		
Power On (Typ.)	250 mA	250 mA	250 mA
Stand by (Typ.)	58 mA	58 mA	58 mA
Operation (Typ.)	224 mA	242 mA	242 mA

Performance

Light Source	Visible Red light 632nm LED
Sensor	Linear Sensor
Processor Type	ARM 32-bit CPU
Operating Freq.	8 MHz (Internal)
Scan Speed	100 scans per second ±10%
Reading Distance	From contact up to 200mm@20mil/0.5mm, PCS90%
Width of Field	40 mm @ Contact, 10mil/0.25mm, PCS90%
Print Contrast Ratio	45%
Resolution	4mil/0.1mm@PCS90%,Code39
Reading Angle	Test Conditions : Code 39, 10mil/0.25mm, PCS 90%
Front	10°~40°(±5°)
Left & Right	± 30°(±5°)
Ambient Light	Fluorescent lamp 10,000 Lux. Maximum

Environmental

Operating Temp.	0°C to 50°C (32°F to 122°F)
Storage Temp.	-20°C to 70°C (-4°F to 158°F)
Relative Humidity	20% to 95% (Non-condensing)

Reliability

Life Time	
Trigger Switch	1,000,000 times @ 1kg ±50g cycles
MTBF(Calculated)	50,000 hours
Thermal Shock	
High Temp.	60°C (140°F)
Low Temp.	-20°C (-4°F)
Cycle time	30 minutes for high temp. , 30 minutes for low temp.
Cycles	24 cycles
Cable Bending Test	40,000 times minimum (30 times/min @ 200g/90°)
Drop	59.05 inches (150cm) drop on Concrete Surface

Readable Symbolologies

	Readable	Default Enable
All UPC/EAN/JAN	✓	✓
EAN128 Code	✓	
Code39	✓	✓
Code39 Full ASCII	✓	
Code32 / Italian Pharmacy	✓	
Code128	✓	✓
CODABAR/NW7	✓	✓
Interleave 25	✓	✓
Industrial 25	✓	
MSI/PLESSEY	✓	
Code 93	✓	
China Postage	✓	
GS1 DataBar	✓	

Due to Champtek's / Scantech ID's continuing product improvement programs, specifications and features are subject to change