



UNIQ: Compact, Powerful, Reliable

UniQ™ marker is a revolutionary and innovative approach to Fiber Laser Marking.

UniQ™ fiber laser marker represent the perfect combination of a high performance fiber laser into a innovative, ultra-compact housing designed to provide an effective solution to the recent request of shorter, smaller production lines, in order to reduce footprint and floor area consumption.

Thanks to its advanced internal design, UniQ™ laser marker does not need any low-IP grade external cabinet, controller or power supply, and is totally free from delivery fiber constraints such as fiber length and fiber bending limitations.

The IP54 rated innovative housing guarantees maximum protection even in harsh factory environments and industrial applications.

UniQ™ laser marker works seamless with Datalogic's Lighter Suite, a powerful, quick and intuitive marking software, and is fully compatible with the latest Datalogic I/O interfaces.



LASER MARKING

HIGHLIGHTS

- Powerful 15W fiber laser source
- All-in-one, Fully integrated ultra-compact device
- Rugged IP54 rated housing
- no external rack, no power supply, no other controller needed
- No fiber delivery constraints
- Built-in second generation EMC (Embedded Marking Controller)
- Great Money/Watt
- Powered by Lighter software Suite

APPLICATIONS

Automotive

unmatched performance on metals

- High resolution, excellent contrast with low thermal impact
- Quick and clear black laser annealing, without cracks damage
- High engraving depth for END -OF-LIFE traceability

Electronics

high contrast marking

- High contrast marking on additivated plastic materials
- High speed coding and branding on industrial electronic devices

Medical & surgical tools

permanent and clean

- Contactless and Clean Direct Marking Process for Branding & Personalization
- Instant permanent marking: no drying time, no post processing, no solvent or additive

Precision Mechanics

high precision marking with no mechanical stresses

- Clear and precise annealing even on very small surface
- Resistant to wear, corrosion, solvent, water and UV



TECHNICAL DATA

Nominal Power	15W
Peak Power	10 kW
Pulse energy	0.75 mJ
Wavelength	1060 – 1080 nm
Laser source	Pulsed Fiber Laser
Modulation	15 kHz ÷ 100 kHz
Pulsewidth (typ)	120 nsec
Marking capabilities	Standing, Rotary axis, On the fly (marking in motion)
Integration	Up to 4 mechanical axis driving capabilities (stepper motor) Up to 10 digital inputs and 10 digital output fully programmable dedicated connectors for Datalogic's Encoder and Photocell
Interface	Ethernet, RS 232, 4x USB
Aiming & Focus Beam	Class II Semiconductor laser @ 635 nm
Temperature Range	5°C to 40°C
Protection degree	IP54
Power Supply	100/240 VAC – 50/60 Hz
Dimension (LxHxW)	497 x 183 x 150 mm
Standard Marking configuration	F – Theta 160 S Marking AREA 100x100 mm ² Working Distance 184 mm F – Theta 254 S Marking AREA 140x140 mm ² Working Distance 294 mm

All laser sources described in this product guide are Class 4 laser sources.

Laser interaction with organic or inorganic material can cause TOXIC FUMES/PARTICLES. The OEM laser components described in this product guide is for sale solely to qualified manufacturers, who shall provide interlocks, indicators and other appropriate safety features in full compliance with applicable national and local regulations.

DIMENSIONS

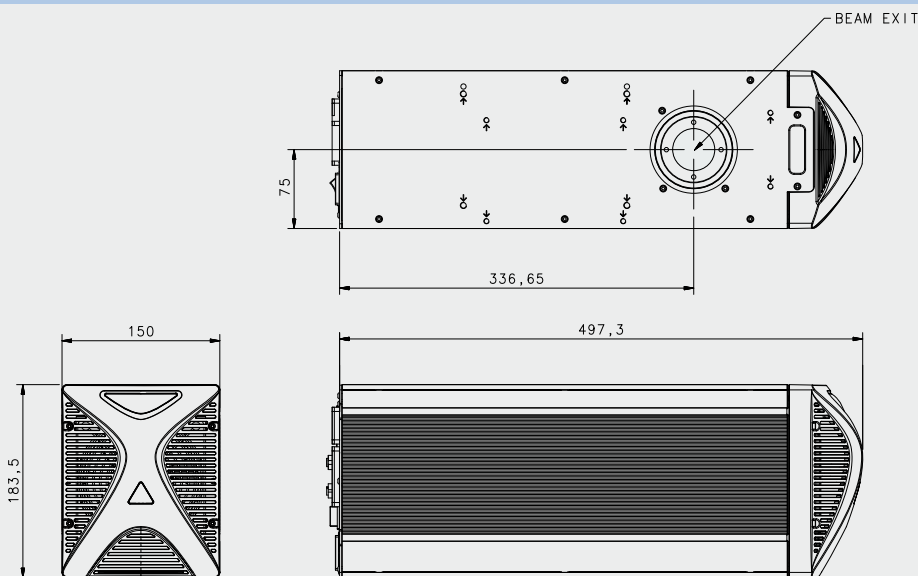

Dimensions in mm

MODEL SELECTION AND ORDER INFORMATION

ORDER NUMBER	DESCRIPTION	FULL DESCRIPTION
986101000	UNIQ 1150-1040 IR Fiber System	UniQ Fiber Laser Marker 15W@1064 Without F-theta Lens
986101010	UNIQ 1150-1340 IR Fiber System	UniQ Fiber Laser Marker 15W@1064 With 160S F-Theta Lens
986101020	UNIQ 1150-1640 IR Fiber System	UniQ Fiber Laser Marker 15W@1064 With 254S F-Theta Lens

ACCESSORIES SELECTION AND ORDER INFORMATION

ORDER NUMBER	DESCRIPTION
985330031	Standard Control Box
985350032	Fan-out Cable
985350033	UniQ Cable Starter Kit

Rev. 00,03/2015